



陽順科技股份有限公司  
Ray-High Technology Co., Ltd.



通過 IP67 (E 認證!!  
IP67 Approved  
CE Certified



## 陽順科技

專業MPG電子手輪，開關，按鍵開發製造廠

## Ray-High Technology

Professional MPG, Switch and Pushbutton R & D Manufacturer

# 陽順科技 追求技術新境界

擁有數十年專業經驗的陽順科技股份有限公司，早期從事工業產品製造及自動化控制系統設計與維修，累積了豐富的實務經驗。秉持卓越的技術背景，再融合理論基礎，陽順科技投入了無數的心血與資金於電子電氣元件的研發工作。

多年來全心致力於技術的研發，陽順公司已取得豐碩的成果，且部份創新設計已榮獲專利。

除了不斷追求技術的創新突破，陽順科技致力於產品達到國際品質標準以及關懷環保。多年來的努力，陽順產品更榮獲**IP67**、**CE** 及**RoHS**的認證通過。

陽順產品具有全電壓的設計，輕、薄、耐摔、觸感佳、防水、防塵、防油、抗靜電、壽命長等諸多特性，深獲國內外客戶的一致肯定。

## Ray-High Technology

### Dedicated To Pursue a New Level of Technology!

**Ray-High** Technology, starting with industrial manufacturing and the maintenance of automatic control systems maintenance, has accumulated over 30 years of experience in control facilities.

Based on those outstanding experiences combining with the theorem, **Ray-High** Technology has put great efforts and capital in the research and development of electronic and electrical devices.

**Ray-High** Technology has reached great achievement through years of total dedication to high-level R & D, and some of the designs have been patented.

In addition to constant pursuance of technological breakthrough, **Ray-High** is also dedicated to achieve international standards for our product quality and environmental protection. Through years of efforts, **Ray-High** products have been certified by **IP67**, **CE** and **RoHS**.

**Ray-High** products integrate many special features, slim lightweight, drop resistance, fine to touch, waterproof, dustproof, oil proof, antistatic and long serving life. These features enable **Ray-High** products to be fully recognized by all customers, from national and international.



# 產品均經過嚴格品質檢測

## Rigorous Quality Inspection

### 適用對象

陽順產品適用於自動化設備，且可依客戶要求量身訂製。  
少量多樣之客製化產品也可歡迎訂購。

### TYPICAL APPLICATIONS

Ray-High products are suitable for automation equipment and able to be customized.  
Even the small quantity orders are available.

- |          |         |                  |                           |
|----------|---------|------------------|---------------------------|
| • CNC控制器 | • 運動控制卡 | • CNC control    | • Motion control card     |
| • 伺服馬達   | • PLC   | • Servo motor    | • PLC                     |
| • 步進馬達   | • 人機介面  | • Stepping motor | • Human machine interface |
| • 單晶片控制器 | • 變頻器   | • Micro CPU      | • Inverter                |

### 產品測試結果



絕緣阻抗測試 (DC500V/2 Sec)  
Insulation resistance test (DC500V/2 Sec)



逆極性電壓測試 (36V/1min)  
Polarity voltage test (36V/1min)



IEC通電試驗 (1KV/60秒以上)  
IEC Transistor shortage test (1KV/60sec)



IEC耐靜電測試 (±10KV)  
IEC electrostatic discharge test (±10KV)



RFI試驗 (144MHz ~ 1.26Hz)  
RFI test (144MHz ~ 1.26Hz)

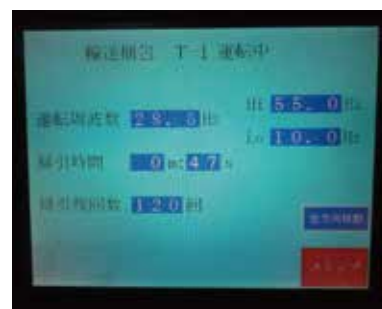

包裝輸送震動試驗 (10-55Hz)  
Packages vibration test (10-55HZ)



MPG壽命試驗 (連續300RPM/500萬轉以上)  
MPG life test (over 5 Mega Rev./300RPM)



落下試驗 (2M高/各向/20次以上)  
Drop test (2M high/XYZ direction/20 times)



耐油測驗 (切削/潤滑油)  
Oil-resistant test (Cutting/lubricating oil)

# P3系列標準型

## 手持操作盒 P3 Series Pendant Station

通過 IP67 (CE 認證!!)  
IP67 Approved  
CE Certified

### 特性

- 輕巧又迷你的設計，掌上握持操作，是單軸控制的**最佳首選**。也可追加使能開關及急停開關，更符合了CE的安全規範要求。
- DC5V-DC24V全電壓輸入及防逆向電壓保護設計。
- 抗電磁干擾設計，耐靜電±10KV。
- 防塵防水防油設計。
- 內置永久磁鐵可外加拖架，使用方便。
- 有標準型及客製化供選，編碼方式有點對點，二進制及灰碼。
- 適用三菱、發那科和西門子等數控系統及自動化設備。

### FEATURES

- Light and small size design for handling is the best selection for uniaxial control. Enabling switch and EMG are optional to meet CE requirement.
- Reversed voltage protection ranges from DC5V to DC24V
- Electrostatic discharge can be measured up to ±10KV
- Dustproof, waterproof, and oil proof
- Embedding magnet to secure the P3 in the included bracket
- Standard model and customer model are available. Encoding scheme comprises point to point, binary system, and gray code
- Applicable for Mitsubishi, Fanuc, and Siemens etc. numerical control system and automation equipments

### 訂購編號 ORDERING INFORMATION

**P 3 - P P 3 - 1 R 5**

3系列

3 Series:

軸規格

P: 點對點 P: Point to point

B: 二進制 B: Binary

G: 葛雷碼 G: gray

Axis Specif.

倍率規格

Multiplication

軸數

Axis No.

3=3軸

4=4軸

5=5軸 (最多8軸)

MPG規格 (參照P.10)

MPG Specif. (Ref P.10)

### 尺寸圖 DIMENSION DRAWING (mm)

#### P3外型尺寸 P3 Dimensions

#### 3系列標準型 3 Series Standard Type



#### 3系列選配 3 Series Optional

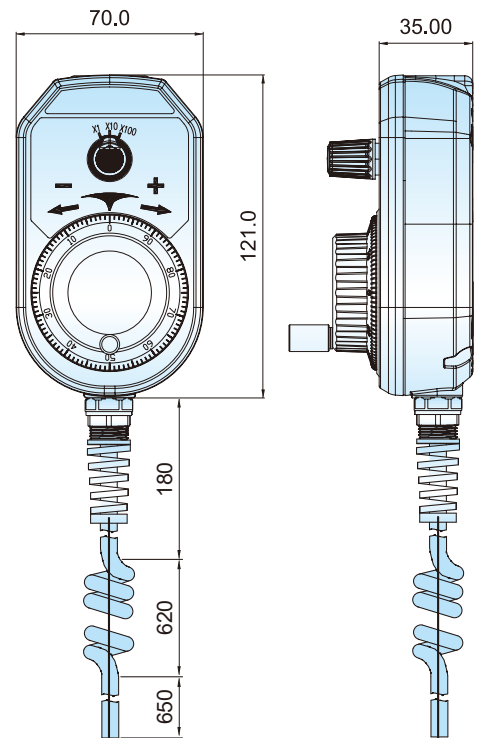

- 拖架與P5共用
- The bracket can be commonly used with that of P5 series.

- ★ 捲線長度可拉3M使用
- ★ The standard flexible wire can extend to 3M

# P5系列標準型

## ▶ 手持操作盒 P5 Series Pendant Station

通過 IP67 (E 認證!!)

IP67 Approved  
CE Certified

### 特性

- 專為東方人體型，作人體工學設計，操作順手方便。
- DC5V~DC24V全電壓輸入及防逆向電壓保護設計。
- 抗電磁干擾設計，耐靜電±10KV。
- 防塵防水防油設計。
- 內置永久磁鐵，及外付吊掛、拖架，使用方便。
- 有標準型及客製化供選，編碼方式有點對點，二進制及灰碼。
- 適用三菱、發那科和西門子等數控系統及自動化設備。

### FEATURES

- Ergonomics design, especially for the orientals. Easy to use.
- Reversed voltage protection ranges from DC5V to DC24V
- Electrostatic discharge can be measured up to ±10KV
- Dustproof, waterproof, and oil proof
- Embedding magnet to secure the P5 in the included bracket
- Standard model and customer model are available. Encoding scheme comprises point to point, binary system, and gray code
- Applicable for Mitsubishi, Fanuc, and Siemens etc. numerical control system and automation equipments

### 訂購編號 ORDERING INFORMATION

**P 5 - P P 3 - 1 R 5**

5系列  
5 Series:

軸規格 Axis Specif.

P: 點對點 P: Point to point

B: 二進制 B: Binary

G: 葛雷碼 G: gray

倍率規格

Multiplication

軸數

Axis No.

3=3軸

4=4軸

5=5軸 (最多8軸)

MPG規格 (參照P.10)

MPG Specif. (Ref P.10)

### 尺寸圖 DIMENSION DRAWING (mm)

5系列標準型  
5 Series Standard Type



P5外型尺寸  
P5 Dimensions

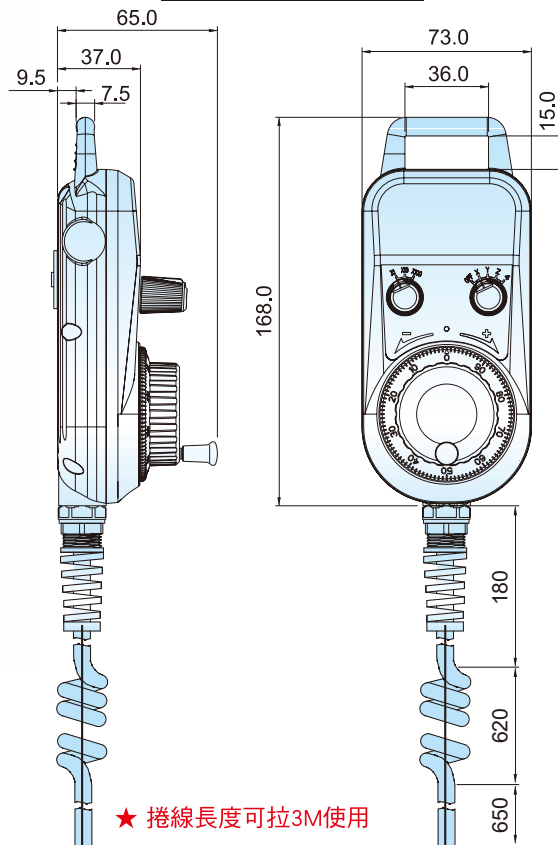

★ 捲線長度可拉3M使用

★ The standard flexible wire can extend to 3M

P3/P5系列共用拖架  
P3/P5 Shared Bracket



P3/P5托架尺寸  
P3/P5 Bracket Dimensions

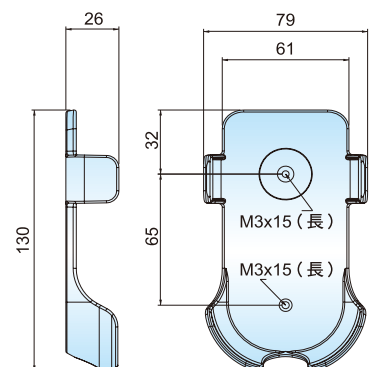

# P6系列專業型客製化

## ▶ 手持操作盒 P6 Series Pendant Station (Professional Customization)

### 特性

- 專為東方人體型，作人體工學設計，操作順手方便。
- DC5V~DC24V全電壓輸入及防逆向電壓保護設計。
- 抗電磁干擾設計，耐靜電±10KV。
- 防塵防水防油設計。
- 內置永久磁鐵，使用方便。
- 適用三菱、發那科和西門子等數控系統及自動化設備。
- 選購品：急停開關、使能開關(2A)按鍵、LED照明裝置，滿足了各種客製化多功能的產品。

### FEATURES

- Ergonomics design, especially for Orientals. Easy to use.
- Reversed voltage protection ranges from DC5V to DC24V
- Electrostatic discharge can be measured up to  $\pm 10KV$
- Dustproof, waterproof, and oil proof
- Embedding magnet to secure the unhooked P7 in the included bracket
- Applicable for Mitsubishi, Fanuc, and Siemens etc. numerical control system and automation equipments
- OPTION: emergency stop switch, push button for enabling switch (2A) and LED lighting device. These items meet customer demands for customization and versatile application.

### 訂購編號 ORDERING INFORMATION

# P 6 - CUSTOM - 1 R 5

6系列  
6 Series:

MPG規格 (參照P.10)  
MPG Specif. (Ref P.10)

### 尺寸圖 DIMENSION DRAWING (mm)

**P6 托架尺寸- (金屬)**  
P6 Bracket Dimensions-(Metal)

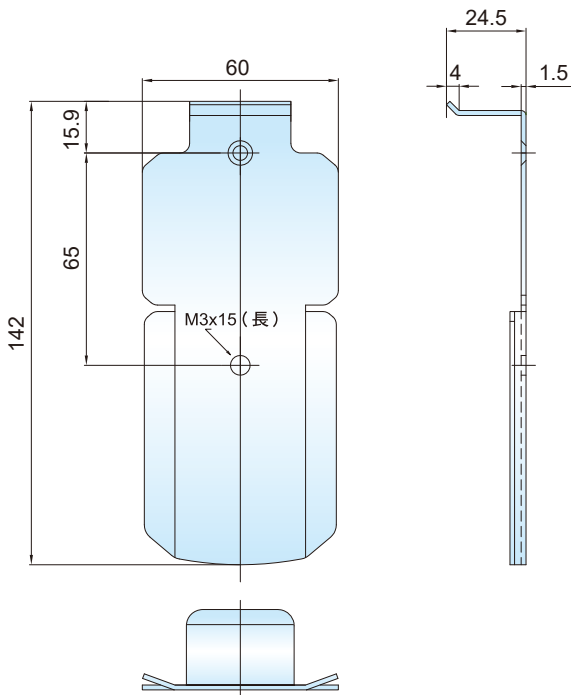

**P6 外型尺寸**  
P6 Dimensions

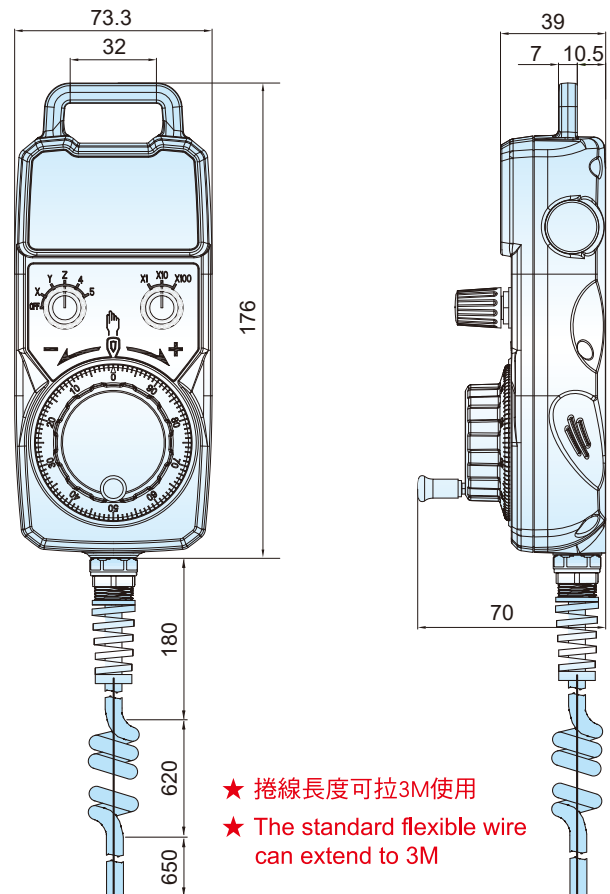

- ★ 捲線長度可拉3M使用
- ★ The standard flexible wire can extend to 3M

通過 IP67 (E 認證!!)  
IP67 Approved  
CE Certified

應用實例 Example

P6-JOG



P6-Light



P6-2R



P6-EMG



P6-K-EMG



P6-R-EMG



# P9系列模組型客製化

## ▶ 手持操作盒 P9 Series Pendant Station (Modular Customization)

### 特性

- 具有多功能及客制化的要求，採用模組化的設計，滿足了少量且多樣的市場需求。採用72mm的大刻度盤設計，適用於歐美市場，華美氣派，滿足了各種專用機及工具機。
- 安全規範上提供了2組2A或2B的按鈕開關可使用。
- 可加裝LED的照明裝置。
- 適用三菱、發那科和西門子等數控系統及自動化設備。

### FEATURES

- Applied for marketing demands, we offer modularized design to meet the need of versatility and customizing. 72mm dial wheels are especially applied for European and American markets for all kinds of machines.
- Two sets of 2A or 2B button switches are provided for safety certificates.
- Mountable LED torch is optional.
- Applicable for Mitsubishi, Fanuc, and Siemens etc. numerical control system and automation equipments

### 訂購編號 ORDERING INFORMATION

# P 9 - CUSTOM - 1 R 5

9系列  
9 Series:

MPG規格 (參照P.10)  
MPG Specif. (Ref P.10)

### 尺寸圖 DIMENSION DRAWING (mm)

**P9托架尺寸-A型 (金屬)**  
P9 Bracket Dimensions-Type A (Metal)

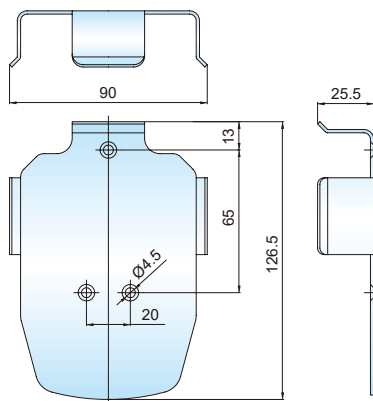

**P9托架尺寸-B型 (塑膠)**  
P9 Bracket Dimensions-Type B (Plastic)

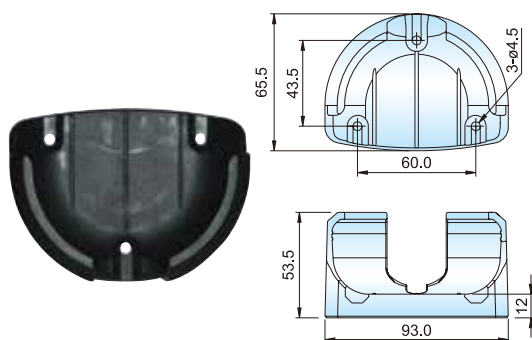

**P9外型尺寸**  
P9 Dimensions

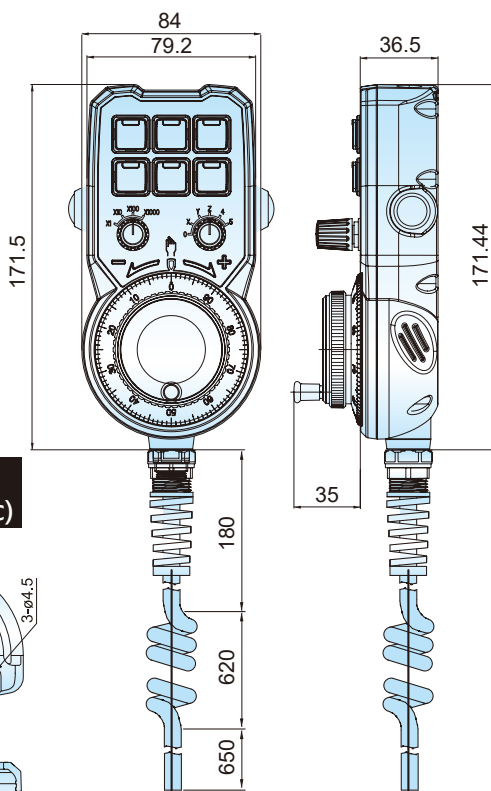

**P9M外型尺寸**  
P9M Dimensions

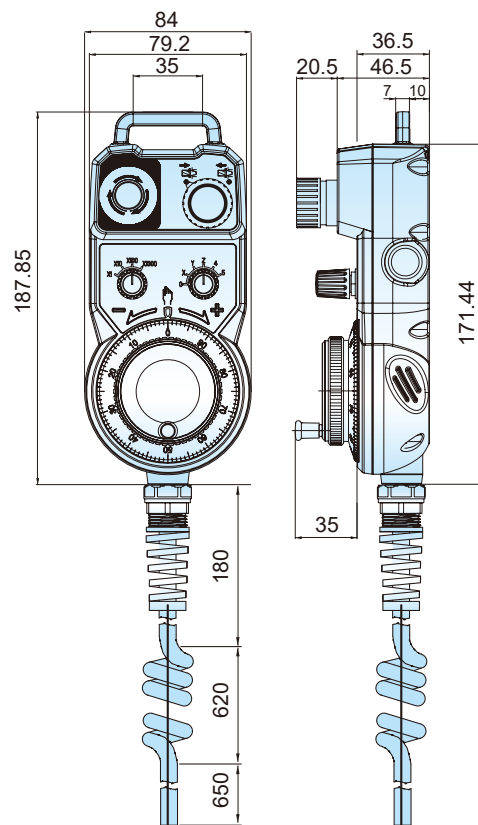

- ★ 捲線長度可拉3M使用
- ★ The standard flexible wire can extend to 3M

- ★ 捲線長度可拉3M使用
- ★ The standard flexible wire can extend to 3M



## 應用實例 Example

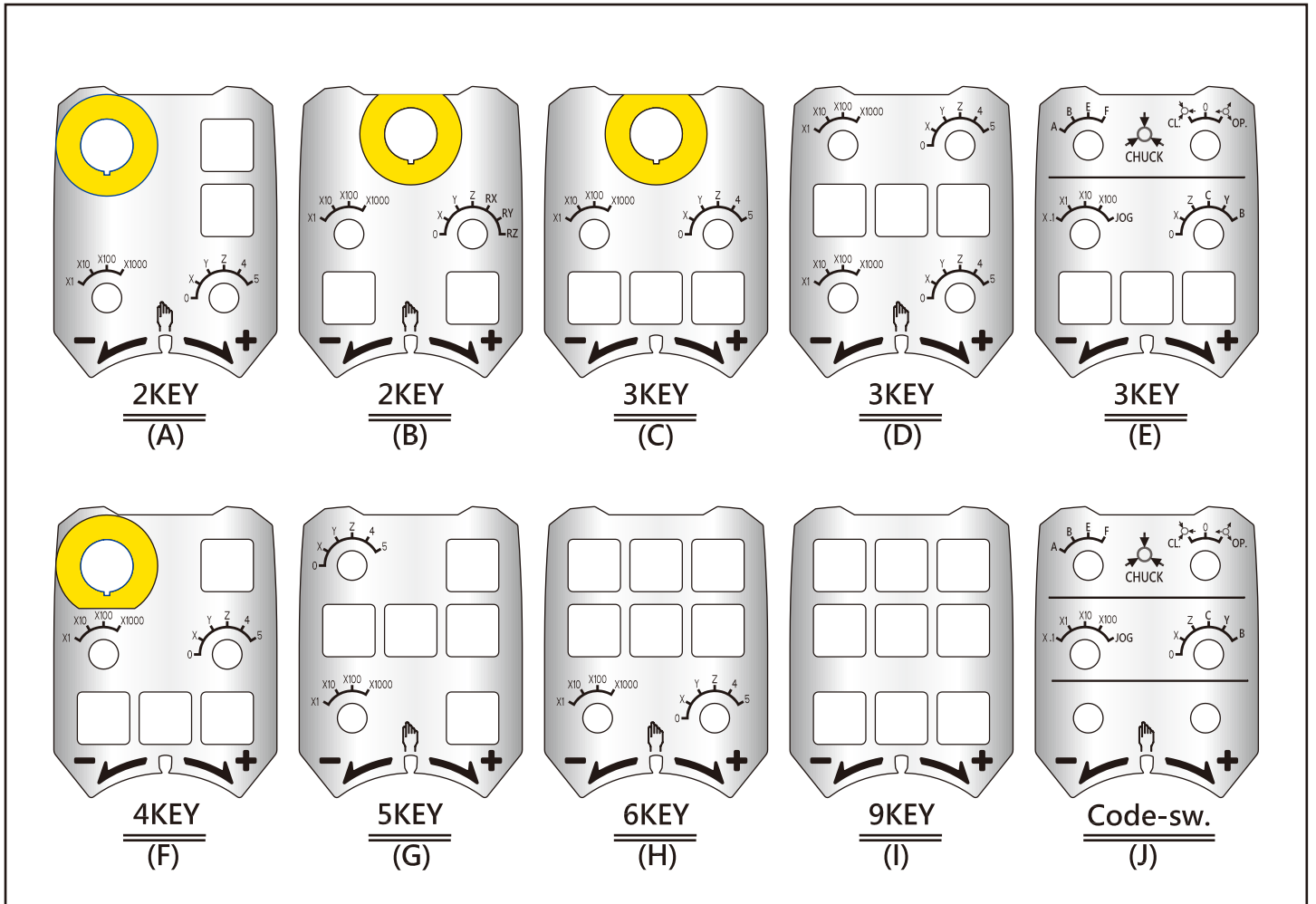

2 Key



2 Key



3 Key



4 Key



6 Key



P9M



# MPG電子手輪 MPG Manual Pulse Generator

## 特性

- 外型優美，手感順，輸入電壓為DC5V~24V全電壓設計質量輕薄，體積小最適用於各種面板的搭配與需求。
- 正逆向電源輸入保護設計，防止誤接燒壞。
- 抗靜電，電路設計可達±10KV。
- 防塵、防水、耐油設計，正面IP67/符合CE。
- 強化的機體設計，壽命達300萬轉次以上。

## FEATURES

- Texture outlooks, smooth handling, small and lightweight with wide supply voltage from DC5V-24V, applicable for wide variety of panels.
- Reversed voltage protection designing to prevent mistake from faulty wiring
- Electrostatic discharge can be measured up to ±10KV
- Dustproof, waterproof, and oil proof for IP67 and CE certified
- Durable structure design ensures the service life up to 3 million rotations

## 尺寸圖 DIMENSION DRAWING (mm)

<p>尺寸圖 Dimensions</p>	<p>鋁金開孔尺寸圖 Hole sizes on sheetmetal</p>	<p>MPG本體 MPG Body</p>
<p>尺寸圖 Dimensions</p>	<p>鋁金開孔尺寸圖 Hole sizes on sheetmetal</p>	<p>5系列 5 series</p>
<p>尺寸圖 Dimensions</p>	<p>鋁金開孔尺寸圖 Hole sizes on sheetmetal</p>	<p>7系列 7 series</p>
<p>BX系列尺寸圖 BX series dimensions</p>	<p>BS系列尺寸圖 BS series dimensions</p>	<p>大手輪 Large Handwheel</p> <p>鋁金開孔尺寸圖 Hole sizes on sheetmetal</p>

通過 (E 認證!!  
CE Certified

## MPG手輪型號說明 MPG ORDERING INFORMATION

1 R 5 - M S 7

1=100PPR  
2=25PPR  
R 或 4 = 電阻式4P 端子台  
D 或 6 = 差動式6P 端子台  
R 或 4= Pull-up type 4P terminal block  
D 或 6= Line driver type 6P terminal block

5=5V 輸出 (差動3.5V以上)  
1=輸入電壓=輸出電壓=開集極迴路(O.C.)  
5 = 5V output  
I = Input voltage = Output voltage = Open Circuit (O. C.)

M=金屬手輪 (鍍Cr白色)  
P=塑膠手輪 (黑色)  
B=大手輪 (電木)  
M = Metallic handwheel  
P = Plastic handwheel  
B = Big handwheel  
C = Silver color coated plastic handwheel

S=面板型  
H=手持單元型  
X=鍍金型  
S = Control panel type  
H = Hand held type  
X = Sheet metal type

7=刻度盤外徑72mm  
5=刻度盤外徑58mm  
4=大手輪外徑140mm  
2=大手輪外徑125mm  
7 = Graduated collar diameter 72 mm  
5 = Graduated collar diameter 58 mm  
4 = Big handwheel diameter 140 mm  
2 = Big handwheel diameter 125 mm

10

## MPG技術參數 MAJOR PARAMETERS

輸入電壓 Input Volt	電壓輸出 Volt Output	最大頻率回應 Max. Freq. Resp	最大輸出電流 Maximum Output Current	上升/下降時間 Tr/Tf Time	工作溫度 Working Temp	儲存溫度 Storing Temp
DC5V DC24V	高：≥ Vcc-0.5V (差動式3.5V以上) 低：≤ 0.1V	1KHz	20mA MAX	10μs以下	-10 ~ 60°C	-20 ~ 70°C
最大功率電流 Max. Power Current	啟動轉矩 Start Torque	軸荷重 Axis Load	最大高轉速 Max. Speed	迴轉壽命 Rotate	重量 Weight	保護機制 Protection
65mA MAX	$1.6 \sim 6.0 \times 10^{-2}$ N.m	軸向Axial：9.8N 徑向Radial：16.6N	瞬間Inst 600RPM 連續Cont 200RPM	300萬迴轉以上 (測試300RPM) Over 3.0 million times rotation	50g 以下 (不含轉盤) (Not incl. dial)	耐靜電Resist of ESD±10KV

## MPG信號迴路 ELECTRIC CIRCUITRY

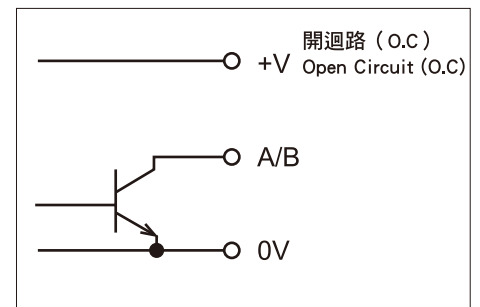
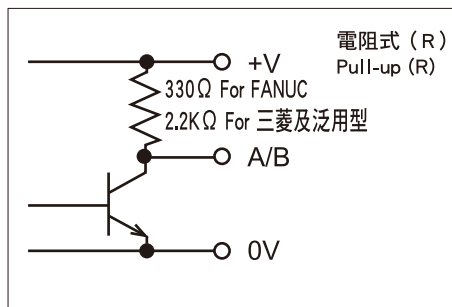
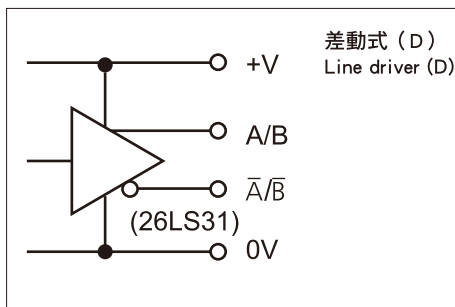

## 標準規格 STANDARD SPECIFICATIONS

序 NO	型號 MODEL	使用對象 APPLICATION	規格 SPECIFICATIONS
1	1DM	西門子 siemens	100 PPR / in 5V / out 5V / 差動式輸出
2	1D5	產業型 industrial type	100 PPR / in 7-24V / out 5V / 差動式輸出
3	1R5	發那科 fanuc	100 PPR / in 5-24V / out 5V / 電阻式輸出
4	2R5	三菱 mitsubishi	25 PPR / in 5-24V / out 5V / 電阻式輸出
5	141	產業型 industrial type	100 PPR / in 5-24V / out 5-24V / O.C 輸出
6	1R1	產業型 industrial type	100 PPR / in 5-24V / out 5-24V / O.C 2.2KΩ 輸出
7	241	產業型 industrial type	25 PPR / in 5-24V / out 5-24V / O.C 輸出
8	2D5	產業型 industrial type	25 PPR / in 5V / out 5V / 差動式輸出
9	161	產業型 (特殊品) industrial type	100 PPR / in 5-24V / out 5-24V / 差動式輸出

# RCP小波段開關 RCP Code Switches (Small-Size)

## 特性

- 小型波段開關，高強度機構設計。
- 採用鍍金雙接點，工作可靠，防止錯誤信號。
- 提供3種編碼：點對點/二進制/葛雷碼。
- 8段選擇，抗靜電，可依客戶需求訂製段數。
- 全密閉構造，具有優異的耐油及防水性能。
- 可選用焊接或連接器連接，方便佈線。
- 應用在手持操作單元和受空間限制應用上。
- $\varnothing 6$ 轉軸一體成型，強度佳，不易斷裂。

## FEATURES

- Small-size code switches featuring a durable structure design with 2-year warranty
- Gold plated double contacts provide reliable performance and prevent error signals
- Provide 3 types of encoding schemes: point to point, binary, and Gray codes
- 8 levels and anti-static charge, customer design is available on request
- Fully sealed enclosure enables waterproof, dustproof, and oil proof
- Choice of soldering or connector for further connection, convenient to wiring
- Easy installation with Pendant Station even in restricted interspaces
- Top-down  $\varnothing 6.0$  shaft body design, strong and durable for abnormal conditions

## 訂購編號 ORDERING INFORMATION

**RCP - 01M - 3**

系列名稱 Series

輸出碼 Output code

位數0-7 Digit

22.5°	00M	點對點，22.5°	Point to Point
	01M	二進制，22.5°	Binary
	03M	葛雷碼，22.5°	Gray
30°	00P	點對點，30°	Point to Point
	01P	二進制，30°	Bin(PNP)
	01N	二進制，30°	Bin(NPN)



RCP-00M (22.5°)



RCP-00P (30°)

## 尺寸圖 DIMENSION DRAWING (mm)

22.5°

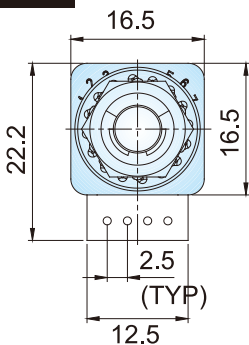

前端定位  
FRONT END POSITIONING

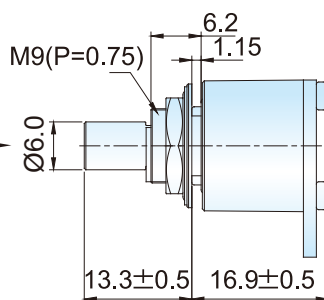

30°

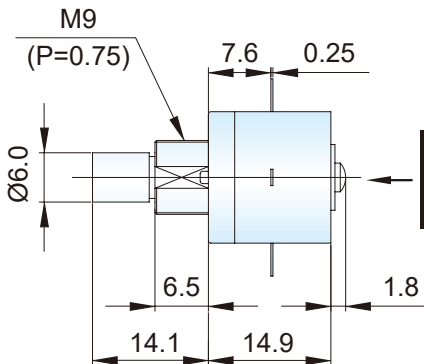
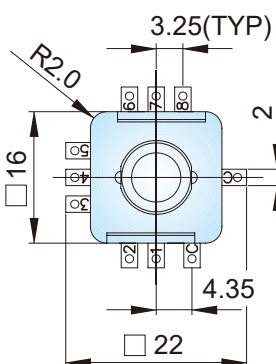

後端定位  
REAR END POSITIONING



應用實例 Example

## 面鉸開孔尺寸圖 CUTOUT DIMENSION (mm)

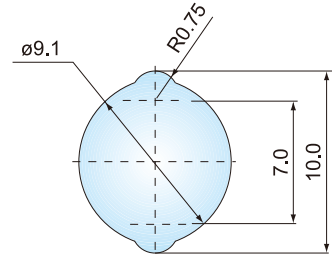



# RDP大波段開關 RDP Code Switches

通過 CE 認證!!  
CE Certified

## 特性

- 用鍍金雙接點，工作可靠，防止錯誤訊號。
- 提供5種編碼：二進制 / 反二進制 / 灰碼 / 反灰碼 / 點對點。
- 高強度機構設計，堅固耐用，2年保固。
- 全密閉構造，具有優異的耐油及防水性能。
- 可調式段位設定，減少庫存規格。
- 可選用焊接或連接器連接，方便佈線。
- 適用於各種操作面板之模式/軸向/倍率/速率/百分比等多段選擇。

## 旋鈕訂購編號

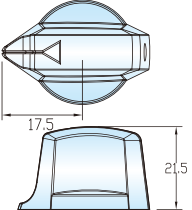
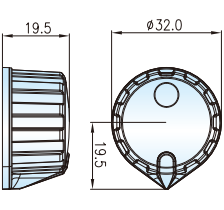
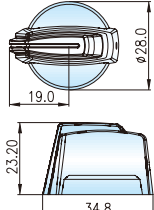
S (標準Standard)	R (圓形Round)	M (金屬Metal)
		
		

## FEATURES

- Gold plated double contacts provide reliable performance and prevent error signal
- Provide 5 types of encoding schemes: binary, anti-binary, Gray code, anti-Gray code, and point to point
- Small sized code switches featuring a durable structure design with 2-year warranty
- Fully sealed enclosure enables waterproof, dustproof, and oil proof
- Adjustable level-stop to minimize the stock inventory
- Choice of soldering or connector for further connection, convenient to wiring
- Excellent for multi-function utilities such as mode, axis, multiplier, speed, and percentage etc. on the operation panel



RDP



DIP 顯示板型 (專利)

隨指標轉動，即時點亮LED，無需增加接點回路。

## 訂購編號 ORDERING INFORMATION

**RDP - 01 H - 16 - CB**

系列名稱 Series

RDP型  
DIP (顯示板型)  
DISPLAY PANEL TYPE  
(PATENT)

輸出碼 Output code

00	點對點	Point to Point
01	二進制	Binary
02	反二進制	Inverse Binary
03	葛雷碼	Gray
04	反葛雷碼	Inverse Gray

代號	旋轉角度 Rotation angle	段數範圍 Step range
H	13.85°	0~25
J	15°	0~23
N	30°	0~11

接線方式 Wiring Method

空白 Blank	焊接型 Soldering
CB	180° 水平入線連接器 180° Horizontal wire connector

## 尺寸圖 DIMENSION DRAWING (mm)

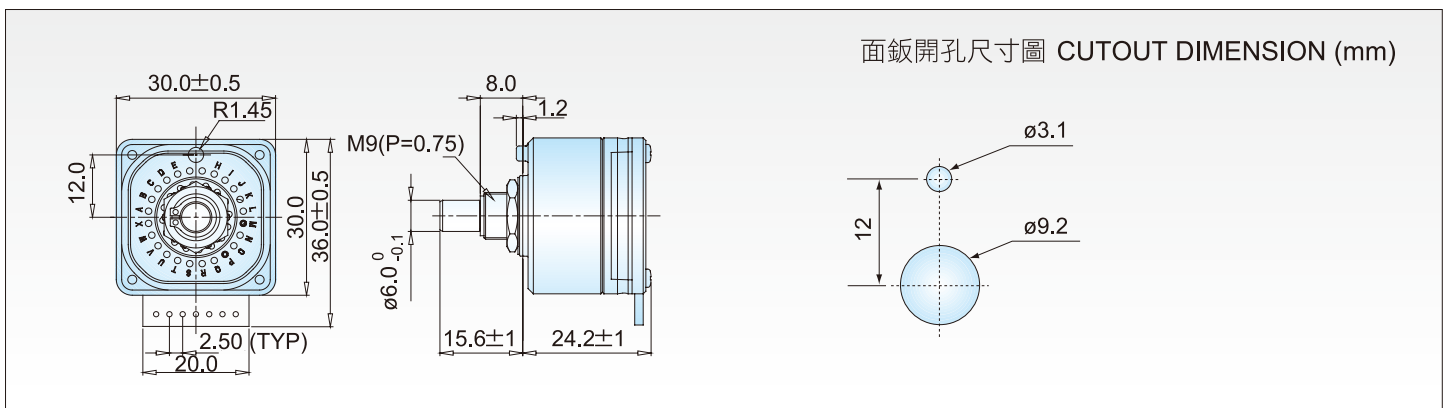

# RHB 經濟型三防按鍵 (IP67)

通過 IP67 (E 認證!!)  
IP67 Approved  
CE Certified

## RHB Economical Three-Proof Push Buttons (IP67)

### 特性

- IP67系列，簡易、經濟型面板按鍵，具防油水、防塵、防卡鍵，三防功能。
- 適用於各種型式版面，面板內側需要植釘處理，面膜覆貼處理。
- 按鍵可單獨使用，或以零間隙之排列使用，不受制式排列限制，面板型式更趨人性化。
- 按鍵材質透光優異，適用雷射刻字，全觀耐用。
- 可與RHB2/4系列共用。

### FEATURES

- The panel push buttons contained in the IP67 series are simple and economical. They feature three-proof functions, such as oil and water proof, dust proof and sticking proof.
- Applicable for various types of panels. The panel inside should be nailing treated and covered by membrane.
- The push buttons can be used individually or arranged with zero gap, which is not restricted by conventional arrangement. This makes panel layout more user-friendly.
- The material of push button features outstanding light transmission. Suitable for laser engraving with maximum durability.
- Can be used together with RHB2/4 series.

台灣專利 大陸專利

13

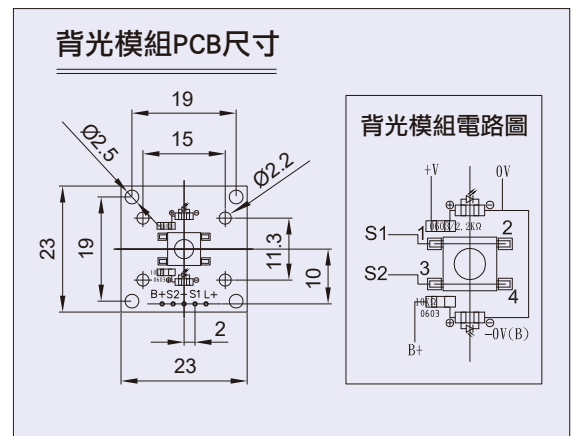
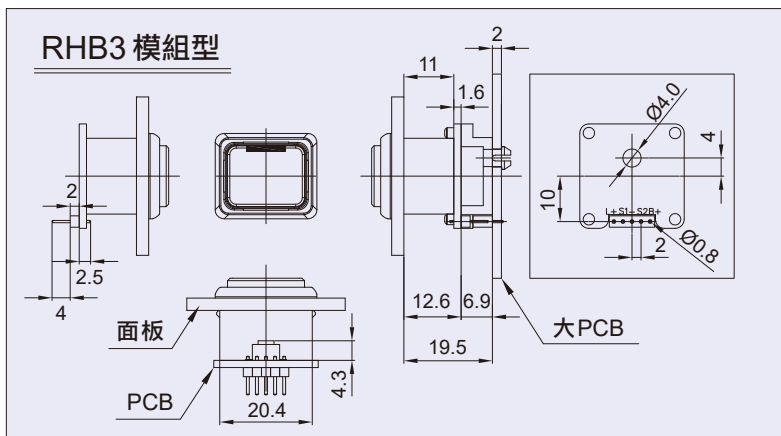
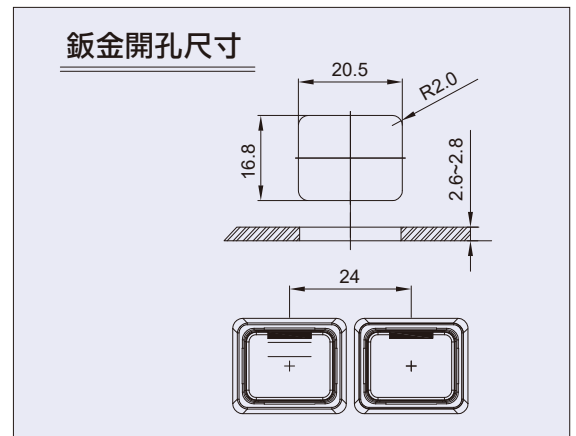
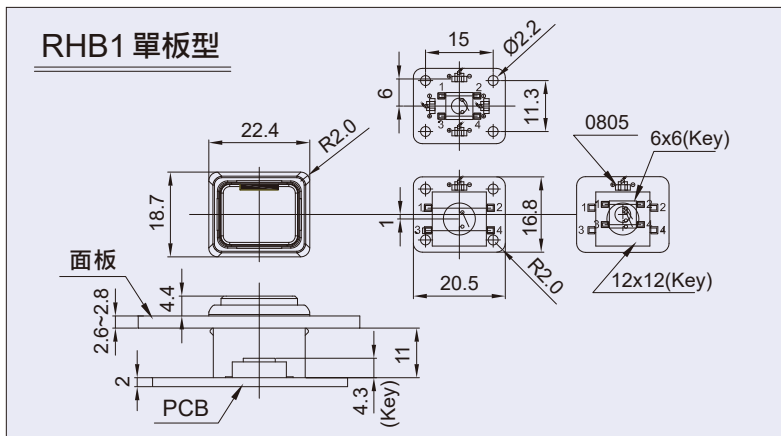

### 訂購編號 ORDERING INFORMATION

# RHB1 - S

RHB1 單板型 Single Plate Type  
RHB3 模組型 Modular Type

銘板編號 Nameplate Information

S	標準型 Standard type
R	環照型 All-round lighting type
M	金屬銘板型 Metal nameplate type



### 應用實例 Example



# RHB 正面更換背光按鍵 (IP65)

## ▶ RHB Direct Swapping Pushbuttons (IP65)

### 特性

- IP65系列，RHB2→單色LED光，RHB4→無LED。
- 直接從面板正向取換LED按鍵模組，免拆卸整片電路板，縮短原廠維修時間與成本。
- 適用於各種型式版面，面板內側可避免多餘的植釘處理，並省下面膜覆貼成本。
- 按鍵可單獨使用，或以零間隙之排列使用，不受制式排列限制，面版型式更趨人性化。

### FEATURES

- IP65 series. RHB2→ single color LED light. RHB4→ without LED.
- Innovative design enables the replacement of the push button direct on the control panel.
- Versatile panel design, nailing of the inner side panel can be avoided and cost saving of the surface membrane.
- Buttons may be installed as single or array appearance, without restrained in restrict styles.



XPB LED模塊

台灣專利 大陸專利

- 可任意排列
- 不受模組限制
- Allows for arranged as desired.
- Not restricted by module.

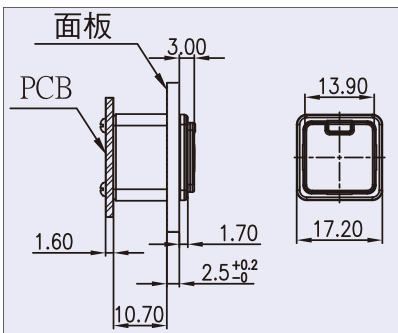

RHB2 RHB4 尺寸圖

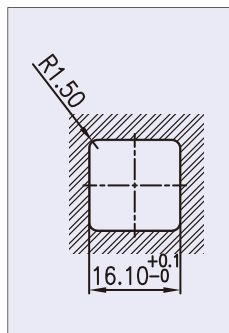

鍍金開孔尺寸

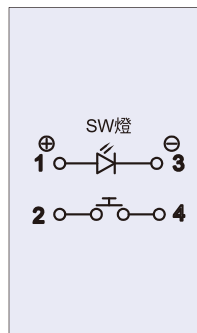

電路圖

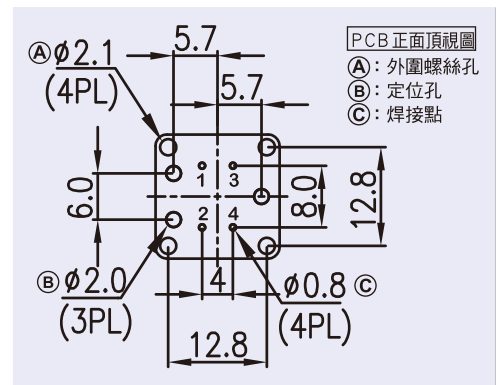

RHB2 RHB4 腳位定義圖

### 應用實例 Example



### 訂購編號

### ORDERING INFORMATION

**RHB2** = 單色LED光源 Single LED

**RHB4** = 無LED Non LED



陽順科技股份有限公司  
Ray-High Technology Co., Ltd.

台灣總公司

陽順科技股份有限公司

24886 新北市五股工業區五工路68巷19號之1

電話：+ 886-2-2290-0825

傳真：+ 886-2-2290-0827

e-mail：tsao.shine@msa.hinet.net

Line ID：tsao.to

WeChat ID：tsao101

http：//www.rhmpg.com.tw



經銷商 AGENT：