

# RHB 經濟型三防按鍵 (IP67)

通過 IP67 (E 認證!!)  
IP67 Approved  
CE Certified

## RHB Economical Three-Proof Push Buttons (IP67)

### 特性

- IP67系列，簡易、經濟型面板按鍵，具防油水、防塵、防卡鍵，三防功能。
- 適用於各種型式版面，面板內側需要植釘處理，面膜覆貼處理。
- 按鍵可單獨使用，或以零間隙之排列使用，不受制式排列限制，面板型式更趨人性化。
- 按鍵材質透光優異，適用雷射刻字，全觀耐用。
- 可與RHB2/4系列共用。

### FEATURES

- The panel push buttons contained in the IP67 series are simple and economical. They feature three-proof functions, such as oil and water proof, dust proof and sticking proof.
- Applicable for various types of panels. The panel inside should be nailing treated and covered by membrane.
- The push buttons can be used individually or arranged with zero gap, which is not restricted by conventional arrangement. This makes panel layout more user-friendly.
- The material of push button features outstanding light transmission. Suitable for laser engraving with maximum durability.
- Can be used together with RHB2/4 series.

台灣專利 大陸專利

13

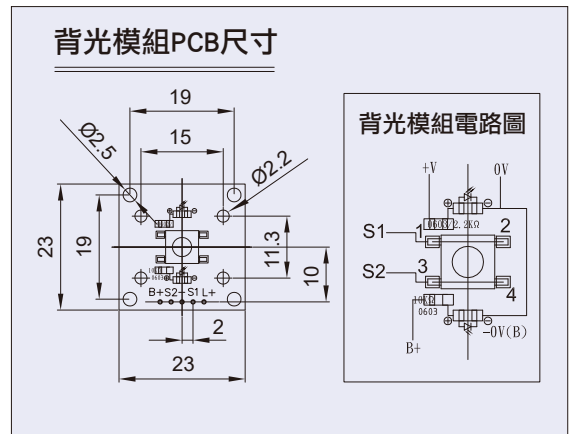
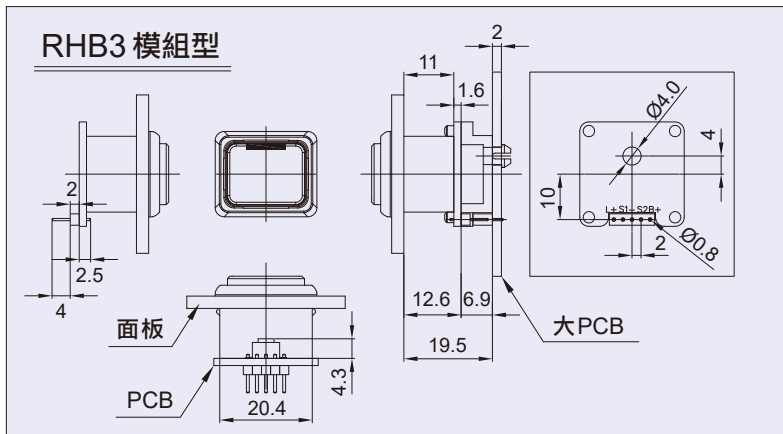
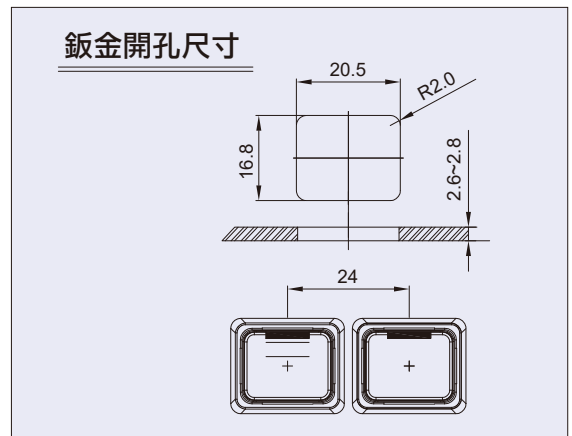
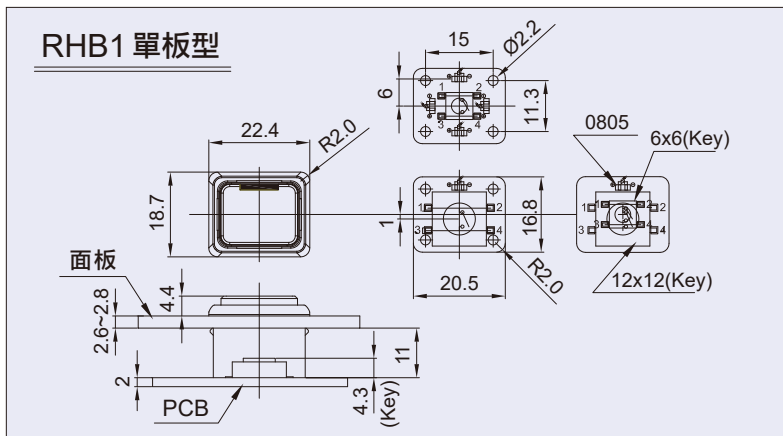

### 訂購編號 ORDERING INFORMATION

# RHB1 - S

RHB1 單板型 Single Plate Type  
RHB3 模組型 Modular Type

銘板編號 Nameplate Information

S	標準型 Standard type
R	環照型 All-round lighting type
M	金屬銘板型 Metal nameplate type



### 應用實例 Example

